

ERKTOR8 *by epcom*[®]



VEKTOR8 MANUAL DE INSTALACIÓN

1. Diagrama de Partes

<p>①EPL-SR8-2700 (AL6005-T5)</p> 	<p>②EPL-MCN2-35 (AL6005-T5)</p> 	<p>③EPL-ECN2-35 (AL6005-T5)</p> 
<p>④EPL-FFN2-03 (AL6005-T5)</p> 	<p>⑤EPL-ALN2-380 (AL6005-T5)</p> 	<p>⑥EPL-ELN2-01 (AL6005-T5)</p> 
<p>⑦EPL-GC-01 (SS304)</p> 	<p>⑧EPL-ES-8/70 (SS304)</p> 	<p>⑨EPL-SCN2-01 (AL6005-T5)</p> 



3. Herramientas necesarias



Guantes



Taladro



Juego de llaves



Flexómetro



Brocas



Llaves hexagonales

4. Instalación :

A) Instalación de soporte delantero y pata telescópica trasera.

1. Realizar un barreno de 10 mm para introducir tornillo expansor.

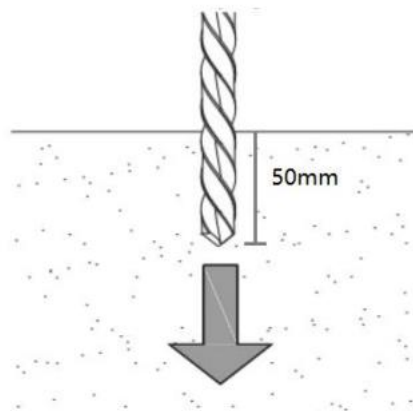

2. Utilice el tornillo expansor para sujetar el soporte frontal y la pata telescópica trasera.

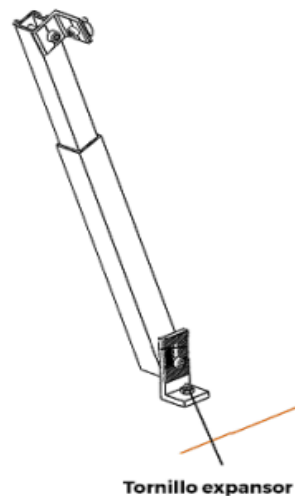
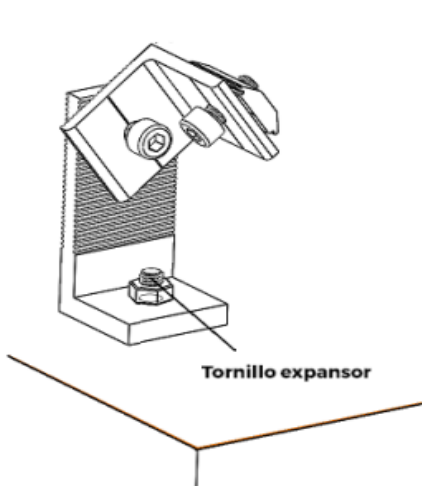

La instalación deberá quedar como se muestra a continuación:

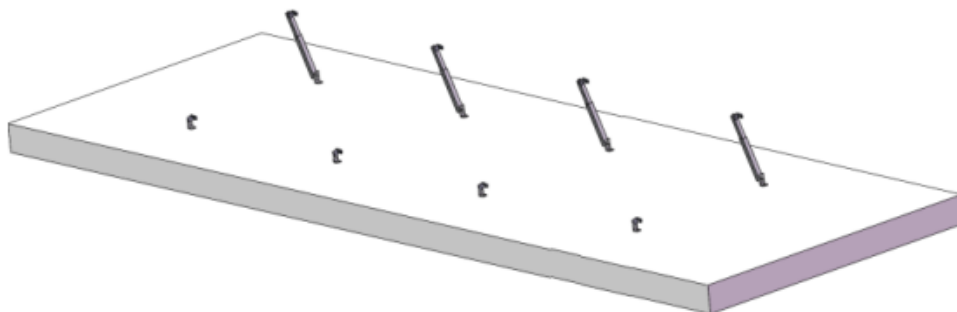

B) Instalación del riel

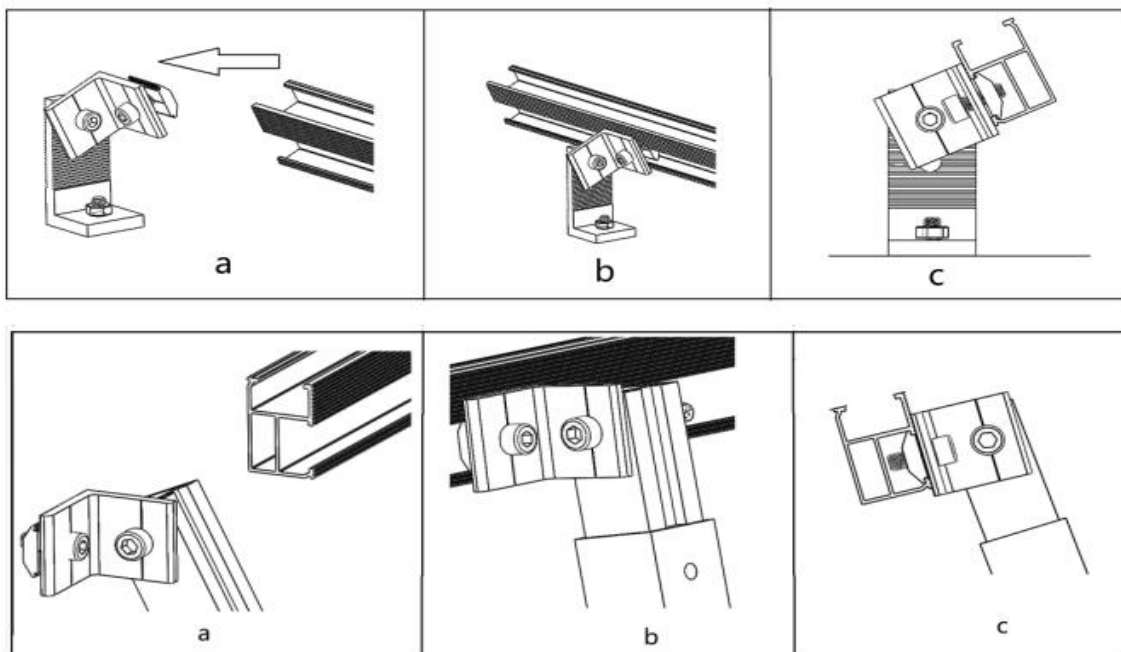

*Dependiendo de la cantidad de módulos solares a instalar, el riel podría requerir un conector para extender la longitud del riel, si es necesario revise el siguiente paso.

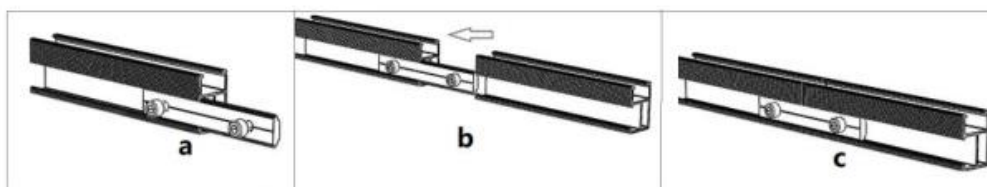

C) Instalación de los módulos FV

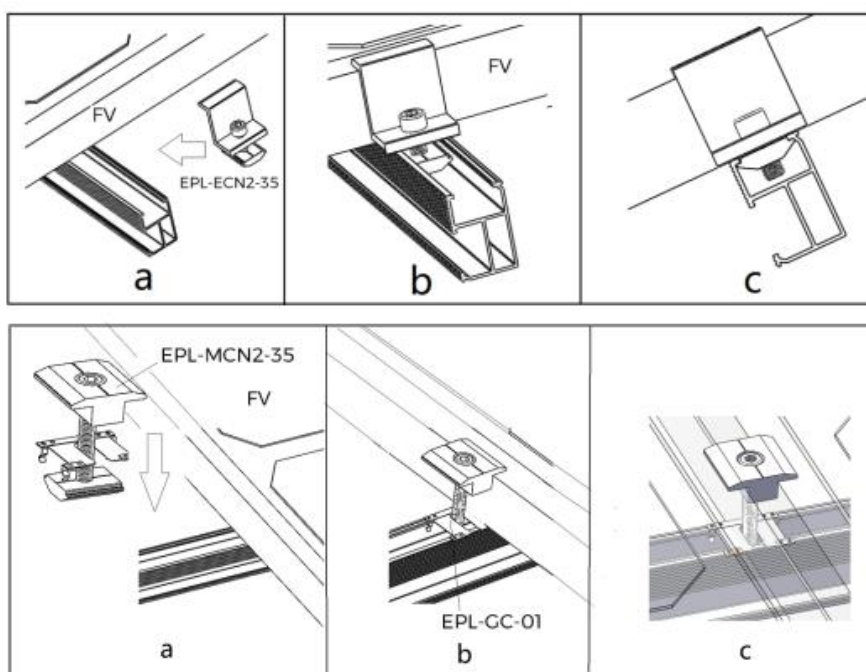

D) Instalación del conector para puesta a tierra.
 Instale el conector de tierra en la orilla del riel.

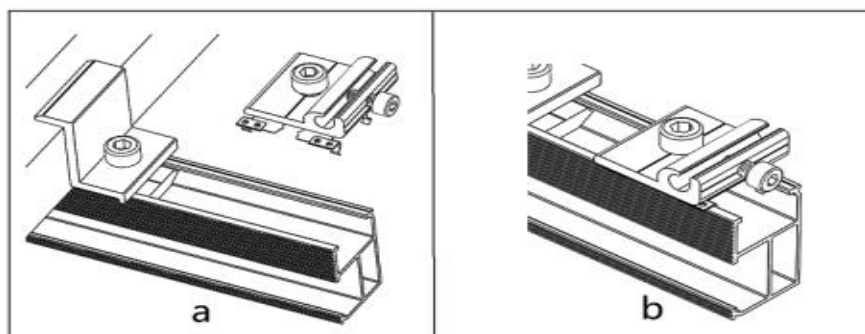

5. Anexos

Para facilitar la instalación del kit de montaje, la siguiente información es para diferentes tamaños de módulos, ángulo de inclinación y velocidades de viento. Puede dirigirse a la siguiente información en caso de ser necesario.

5. Anexos

Para facilitar la instalación del kit de montaje, la siguiente información es para diferentes tamaños de módulos, ángulo de inclinación y velocidades de viento. Puede dirigirse a la siguiente información en caso de ser necesario.

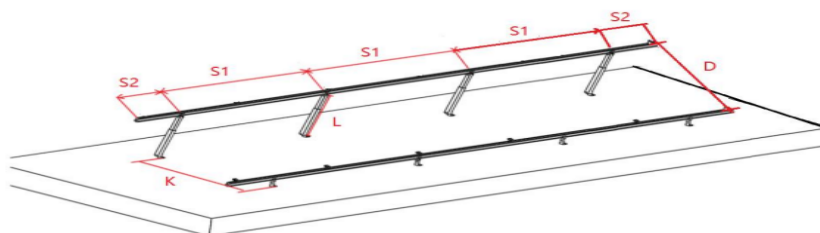

Wind Load		Angle	2172*1303*35				
MPH	KMH		S1 (m)	S2 (m)	K (m)	D (m)	L (m)
85	137	10°	1.45	0.525	1.6	1.23	0.435
		15°	1.45	0.525	1.45	1.33	0.437
		20°	1.45	0.525	1.45	1.33	0.56
		25°	1.45	0.525	1.45	1.33	0.682

Para optimizar la generación de energía del arreglo FV y maximizar la eficiencia se debe de considerar el espaciamiento entre hileras de módulos FV, el cual dependerá de la altura y las dimensiones de los módulos FV. Para calcular el espaciamiento puede referirse a la siguiente fórmula.

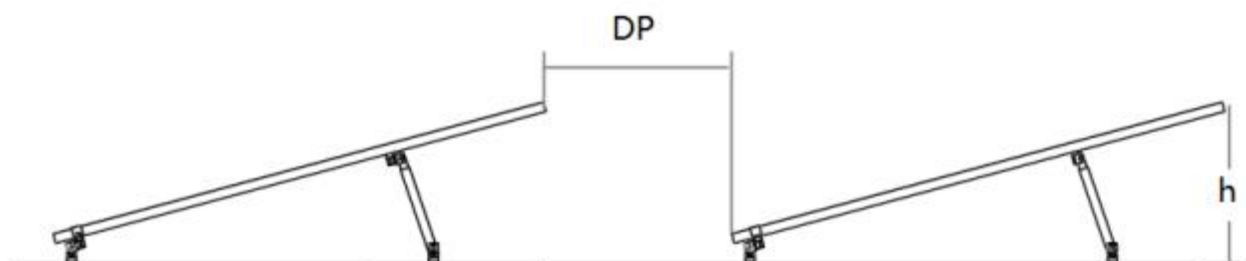

$$Dp = \frac{h}{\tan(61^\circ - \text{grados de latitud})}$$



En la siguiente tabla se muestra información sobre las principales ciudades de México.

Ciudad	Latitud	Ángulo de Instalación	Módulos 72 Celdas	Módulos 60 Celdas
			Espaciamiento	Espaciamiento
Ciudad de México	17°	10°	0.45m	0.36m
		15°	0.65m	0.52m
		20°	0.85m	0.68m
		25°	1.05m	0.83m
Guadalajara	19°	10°	0.48m	0.39m
		15°	0.7m	0.56m
		20°	0.91m	0.73m
		25°	1.1m	0.89m
Monterrey	24°	10°	0.57m	0.46m
		15°	0.83m	0.66m
		20°	1.1m	0.86m
		25°	1.3m	1.05m



Image	Recommended torque
 M8 Bolt*M8 Nut	13 N/m
 M10 Bolt*M10 Nut	25.8 N/m
 M8 Bolt*M2 Nut	11 N/m