

APPROVAL SHEET



MODEL : **PLUSB2500**

DESCRIPTION : **5 Vcc / 2.5 A**

SUBJECT: SCOPE OF DOCUMENT

CONTENTS

1. General Description	4
2. Environment Protection Laws.....	4
3. According with Safety and EMC Criterion.....	4
4. Safety and EMC Approval	4
5. Test Circuit.....	4
6. Input Characteristics	5
6.1 Rated Input Voltage	5
6.2 Input Voltage Range	5
6.3 Rated Frequency	5
6.4 Frequency Range	5
6.5 AC Input Current	5
6.6 Peak Inrush Current	5
6.7 Standby	5
6.8 Efficiency.....	5
7. Output Characteristics.....	5
7.1 Rated Output Voltage	5
7.2 Rated Output Current.....	6
7.3 Rated Power.....	6
7.4 Ripple and Noise.....	6
7.5 Protection.....	6
7.5.1 Over Current Protection	6
7.5.2 Short Circuit Protection	6
8. Reliability Items	6

8.1	Electrostatic Discharge	6
8.2	Insulation Resistance	6
8.3	Leakage Current.....	6
8.4	Hi-Pot Test)	7
8.5	Burn-In Test.....	7
9.	Mechanical Requirement	7
9.1	Dimension.....	7
9.2	Weight.....	7
9.3	Input Plug Type.....	7
9.4	Vibration Test Requirement.....	7
9.5	Bending Test	8
9.6	Drop Test	8
9.7	Plug in and out Test	8
9.8	Salty Fog Test for Metal Part.....	8
<hr/>		
9.9	Case/Resin materials	8
10.	Environmental Performances.....	9
10.1	Operating temperature range.....	9
10.2	Stored temperature range	9
10.3	Operating at the invariable temperature and invariable humidity.....	9
11.	DC Output Cable and Plug Drawing	10
12.	Product Outline Drawing.....	11
13.	Ratin Label Drawing	12
14.	Packing.....	13

1. General Description

2. This specification defines the input, output, performance characteristics, and environment, noise and safety requirements for 12.5 **Watts** adaptor. The adaptor is full range AC

3. Environment Protection Laws (环保法规)

- ROHS REACH CPSIA
- EN71 PHTHALATE HALOGEN

According with Safety and EMC Criterion

- EN60950-1 EN61558-1 EN60065-1 EN55022
- UL60950-1 UL1310 UL60065-1 EN55024
- GB4943-2011 GB9254-2008 YDT 1591-2006
-

4. Safety and EMC Approval

- CB TUV/GS CE PSE ■ UL ■ FCC
- SAA C-tick KC CCC TLC E-mark
-
-

5. Test Circuit

If the test is not to be made on a specified circuit, be sure to use the following circuit.

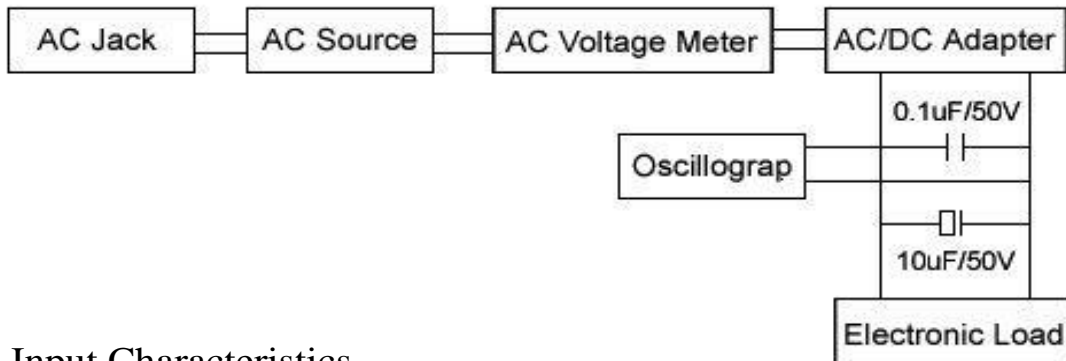

6. Input Characteristics

6.1 Rated Input Voltage

6.2 Rated input voltage is from **100Vac** to **240Vac**.

6.3 Input Voltage Range

Input voltage range is from **90Vac** to **264Vac** input AC voltage.

6.4 Rated Frequency

6.5 It is normal for **50Hz** or **60Hz** and single phase.

6.6 Frequency Range

The adaptor shall operate with an input frequency from **47Hz** to **63Hz**.

6.7 AC Input Current

The maximum input current shall be less than **0.6A** at 100~240Vac input

6.8 Peak Inrush Current

With cold starting, input AC 240V the inrush current should **30A Max**

6.9 Standby

The input power shall be less than **0.1W** at **115 or 230Vac** input.

6.10 Efficiency

Measured at 115Vac or 230Vac input voltage, 100% load ,The efficiency is **80.21% MIN**

7. Output Characteristics

7.1 Rated Output Voltage

7.2

7.3 No load voltage: **5.0V ± 5%** Full load voltage:
5.0V ± 5%

7.4 Rated Output Current

The output current will be performed from **2.5A** at CC mode.

7.5 Rated Power

This adaptor is capable to support **12.5Watts** continuously at all specified conditions.

7.6 Ripple and Noise

Ripple voltage is **120mV** p-p (Full load **2.5A**) measured methods: Performed by 20MHz bandwidth in oscilloscope Applied 0.1uF ceramic capacitor and 10uF electrolytic capacitor across output connector terminals Measured at the end of DC cable.

7.7 Protection (保护)

7.7.1 Over Current Protection

4A maximum with auto-recovery function at 100~240Vac input

7.7.2 Short Circuit Protection

The adaptor is protected that a short happened between the output terminals and shall not result in a fire hazard, any damage to this adaptor and will be normal operation automatically while the short is removed.

8. Reliability Items

8.1 Electrostatic Discharge

At 150pF : 330Ω, for each point, 10 shots of direct discharge or air discharge.(1 MΩ/SHOT), have no malfunction. Direct discharge: **±4kV**, Air discharge: **±8kV**

8.2 Insulation Resistance

At **25°C** after DC 500V 1min between input plug-DC plug, insulation resistance **20MΩ** min

8.3 Leakage Current

5mA maximum, at nominal AC input voltage and frequency

8.4 Hi-Pot Test

Primary to Secondary: 3000Vac /5mAMax / 3second

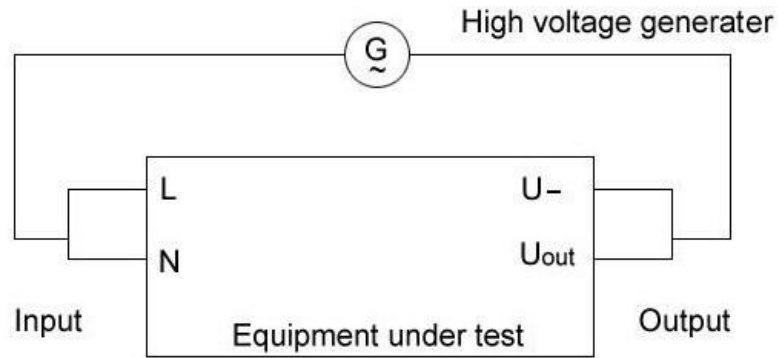

8.5 Burn-In Test

4 hours at 40°C maximum, Normal input voltage, rated load.

9.1 Mechanical Requirement

9.2 Dimension

9.3 Weight

40 10g

9.4 Input Plug Type

Wall-mounted type UL-pin. 2 Conductors, < Live. Neutral >

9.5 Vibration Test Requirement

(Non-operating, with packing) Reference to IEC 68-2-6 .

Test conditions		Acceptance Criteria
Frequency	10~50Hz	Nominal functional test should be satisfied after the test
Sweep	2hours, For each axis(X, Y, Z)	
Acceleration	2.0G (10~50Hz, peak-peak),	
Displacement	0.35 mm(10~50Hz)	

9.6 Bending Test

Fix the adaptor and its plug, apply a load of 300g to the other end, turn the cable by $\pm 60^\circ$ carry out this process 2000 times, at the rate of 20 times per minutes. No abnormality in mechanical and electrical characteristic and disconnection within 30% after the test.

9.7 Drop Test

Drop the adaptor from a height of 100cm onto a hardwood floor, hitting the adaptor for 3 times, no mechanical damages or other failures, no electrical deterioration and other failures comparing to before test condition.

9.8 Plug in and out Test

After plug the connector in (35N max) and out (10N min) the female-connector within 12.5mm/min, then plug in and out for 1500 times, light damage in the mechanic characteristic, but no abnormality in electric characteristic.

9.9 Salty Fog Test for Metal Part

9.10 Experiment condition, Salty water thickness: 5%, Equipment

Temperature: 35~40°C,

put the adaptor (unpacking) in the test equipment for 8h, after 8h recovery at 25°C checking the appearance, the metal parts have no erode and rust.

9.11 Case/Resin materials

Flame resistance applies to 94V-0 or 94V-1

9. Environmental Performances

10.1 Operating temperature range

The product should operate at 0~40°C test of operating for 4 hours at 0°C and 40°C 2°C

2°C

10.2 Stored temperature range

The product should be stored at -25~70°C, test of non-operated for 16 hours at -25°C 2°C and 70°C

2°C

10.3 Operating at the invariable temperature and invariable humidity

The product should operate at 40°C 2°C90~95%RH, test of operating for 48

hours(full

load)