





# Table of Contents

- 1 General Information ..... 1
  - 1.1 Safety Messages ..... 1
  - 1.2 Validity ..... 2
  - 1.3 Safety Precautions ..... 2
- 2 Product Overview ..... 5
  - 2.1 Components of PV Grid-Connected System ..... 5
  - 2.2 Schematic Diagram ..... 6
  - 2.3 Appearance of Inverter ..... 6
  - 2.4 Weights and Dimensions of Inverter ..... 7
  - 2.5 Specifications ..... 8
- 3 Unpacking and Storage ..... 11
  - 3.1 Unpacking Inspection ..... 11
  - 3.2 Storage ..... 11
- 4 Installation ..... 12
  - 4.1 Mounting Location ..... 12
  - 4.2 Mounting the Inverter ..... 13
    - 4.2.1 Clearance ..... 13
    - 4.2.2 Installation Procedure ..... 13
- 5 Electrical Connection ..... 15
  - 5.1 Safety Precautions ..... 15
  - 5.2 Electrical Connection Diagram ..... 16
  - 5.3 Cable Requirements ..... 17
  - 5.4 DC Connection ..... 18
  - 5.5 AC Connection ..... 20
  - 5.6 Second Protective Earth Connection ..... 21
  - 5.7 Connection of Anti-Backflow Meter (Optional) ..... 22
- 6 Installing the Communication Module ..... 24
- 7 Operation ..... 26
  - 7.1 Switching On ..... 26
  - 7.2 Switching Off ..... 26
  - 7.3 LED Indicator Lights ..... 27
- 8 Monitoring ..... 28
  - 8.1 Professional Edition App ..... 28
    - 8.1.1 Software Installation ..... 28
    - 8.1.2 Registration & Login ..... 28
    - 8.1.3 Create Plant ..... 30
  - 8.2 Home Edition App ..... 33
    - 8.2.1 Software Installation ..... 33
    - 8.2.2 Registration & Login ..... 33
    - 8.2.3 Create Plant ..... 34
- 9 Troubleshooting for Fault Messages Displayed on APP ..... 36











# 1 General Information





## 1.1 Safety Messages

Read the manual carefully to become familiar with the equipment before trying to install, operate, service or maintain it. The following safety messages may appear throughout this manual or on the equipment to warn of potential hazards.

	<b>DANGER</b> <b>DANGER</b> indicates a hazardous situation which, if not avoided, will result in death or serious injury.
	<b>WARNING</b> <b>WARNING</b> indicates a hazardous situation which, if not avoided, could result in death or serious injury.
	<b>CAUTION</b> <b>CAUTION</b> indicates a potentially hazardous situation which, if not avoided, could result in minor or moderate injury.
	<b>NOTICE</b> <b>NOTICE</b> is used to address practices not related to physical injury, but to property damage.
	<b>NOTE</b> <b>NOTE</b> is additional information in the manual, which is emphasis and supplement to the contents and provides prompts that are valuable for the optimal installation and operation.

This manual and device may also use the following electrical symbols and identification, shown as follows:

Symbol	Description	Symbol	Description
	DC		Voltage negative pole
	AC		Voltage positive pole
	Earth (Ground)		Off (Power supply)
	Protective earth		On (Power supply)
	Frame or chassis terminal		Refer to the manual description

	Caution, risk of electric shock		Warning of danger
	Caution, hot surface		Danger alert of electric shock. Energy storage timed discharge (time to be indicated adjacent to the symbol)

## 1.2 Validity

This manual is valid for the following residential single phase on-grid PV inverters (hereinafter referred to as inverter):

2 kW / 2.5 kW / 3 kW / 3 kW – D / 3.68 kW / 4 kW / 4.6 kW / 5 kW / 6 kW / 7kW

## 1.3 Safety Precautions

Follow the precautions and special safety instructions provided in the manual when operating the products. Our company will not be liable for any consequences that are caused due to violations regarding general safety regulations and equipment design, production, and usage safety standards.

### Disclaimer

Our company shall not be liable for any consequence caused by any of the following events:

- Damage caused by transportation
- Storage conditions that do not meet the requirements specified in this document
- Incorrect storage, installation, or use
- Installation or use by unqualified personnel
- Failure to comply with the operation instructions and safety precautions in this document
- Operation in extreme environments which are not specified in this document
- Operation beyond specified ranges
- Unauthorized modifications to the product or software code or removal of the product
- Device damage due to force majeure (such as lightning, earthquakes, fire, and storms)
- Warranty expiration without extension of the warranty service
- Installation or use in environments which are not specified in related international standards



**DANGER! High voltage may result in death or serious burns!**

- Operations on the inverter must be performed by qualified personnel.
- PV arrays exposed to light may generate dangerous voltage.
- Do not touch the electriferous modules in the PV system while the inverter is running.
- Carefully read the safety precautions in this manual.



**DANGER! Do not touch the contacts or terminals connected to the grid or the equipment, or it may result in electric shock to death or outbreak of a fire!**

- Do not touch the terminals or conductors connected to the grid circuit.
- Read and understand all instructions and safety precautions for grid connection.
- Follow all the safety precautions for low voltage power grid.



**DANGER! The damaged device or system fault may result in electric shock or outbreak of a fire!**

- Check if there is damage or other dangerous conditions for the device before operation.
- Check if the external device and circuit connection are in a safe state.
- Make sure the device is in a safe state for operating.



**WARNING!**

- The inverter can be connected to the grid only if it gets permission from the local electric power department.
- All electrical installations must be made in accordance with national and local standards and regulations.



**WARNING! Operation by non-professional may result in death or severe burns.**

- Only trained electrically qualified persons are permitted to do electrical operation on this product.
- During maintenance, it is necessary to ensure that at least two staff members work in the field; the breakers of AC terminal and DC terminal must be fully disconnected for at least 10 minutes for internal energy storage components discharging completely, which should be confirmed with a voltmeter.



**NOTICE! Contact or improper operation on printed circuit board or other electrostatic sensitive components may result in damage to the components.**

- Avoid unnecessary contacts with circuit boards.
- Comply with electrostatic protection standards, wear an antistatic wrist strap.

- When installing PV arrays during the day, opaque material should be used to cover the solar battery arrays, otherwise, the solar array will generate high voltage under sunlight.
- The input DC voltage must not exceed 600 V, and the excessive voltage may result in damage to the device.
- The inverter must be properly transported, stored, assembled, installed, operated and maintained.
- All operations and wiring must be made by qualified personnel only to ensure that all electrical installations meet the electrical installation standards. In order to ensure safe operation, the device should be grounded properly and provided with necessary short circuit protection.
- Ensure that DC side and AC side have no electric charge before maintaining or checking the inverter.
- The capacitor in the inverter may present a shock hazard even all connections of the inverter are disconnected. Therefore, the device should be maintained and operated after turning off the inverter for at least 10 minutes.
- Follow all the instructions in this manual.
- The inverter will generate heat during operating, do not touch the radiator and other hot components of the inverter during operating to avoid burns.

## 2 Product Overview

### 2.1 Components of PV Grid-Connected System

PV grid-connected system consists of PV modules, PV grid-connected inverters, metering device and power distribution system. The solar energy is converted into DC via PV modules, and then the DC is converted into sinusoidal AC which has the same frequency and phase as the utility grid and fed into the utility grid via inverters.

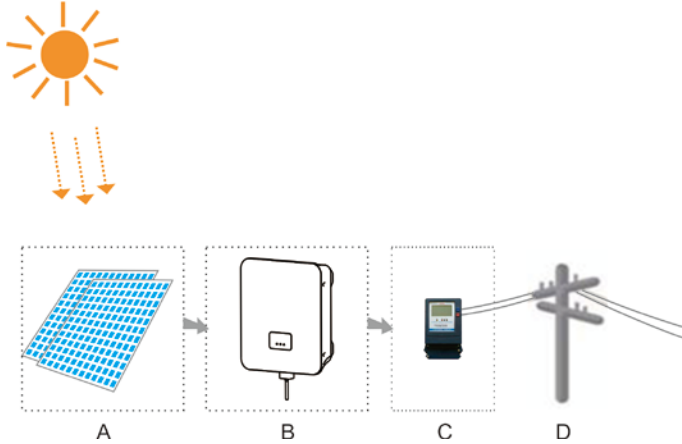

Components	Description
A PV modules	Monocrystalline silicon, polycrystalline silicon, and thin-film batteries with II level protection and no need to be grounded
B Inverter	2 kW / 2.5 kW / 3 kW / 3 kW-D / 3.68 kW / 4 kW / 4.6 kW / 5 kW / 6 kW / 7 kW
C Electric meter	Standard measuring tools for inverter output power
D Utility grid	TT, TN-C, TN-S, TN-C-S

## 2.2 Schematic Diagram

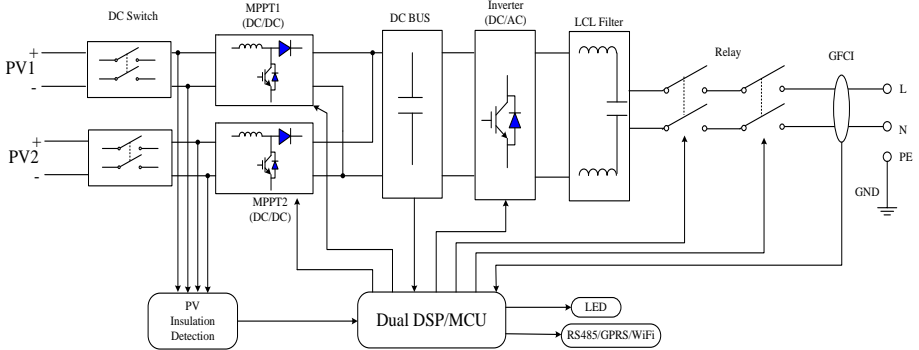

**Note:** The above figure is the schematic diagram of 3 kW-D / 3.68 kW / 4 kW / 4.6 kW / 5 kW / 6 kW / 7kW inverters. A single input is applied to 2 kW / 2.5 kW / 3 kW inverters.

The inverter topology consists of boost and inversion. PV input feeds into the public power grid via DC filtering, boosting, DC bus decoupling, inverter and AC filtering. It adopts DSP and MCU dual-chip redundancy technology to realize fault detection and protection of the inverter. The interior of the inverter has two groups of relays connected between the inverter circuit output and power grid port, and the groups of relays have self-test function that can ensure reliable disconnecting of the connection between the inverter circuit and the utility grid in the event of a failure. It realizes the remote monitoring of the PV power generation system via the communication methods of RS485, GPRS and Wi-Fi.

## 2.3 Appearance of Inverter

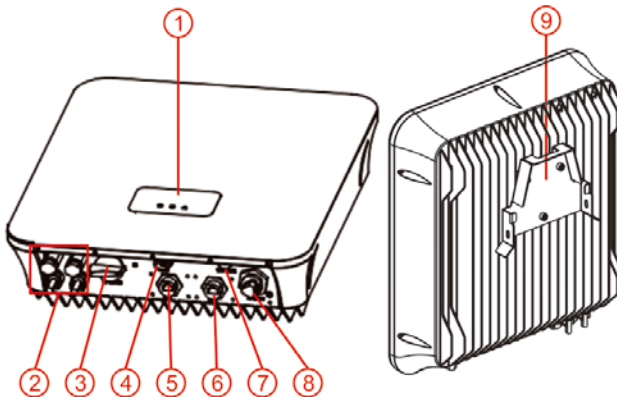

No.	Description	Explanation
①	LED display panel	To display the inverter running state / communication status
②	DC input terminals	To connect inverter to PV modules
③	DC switch	To directly control DC input On / Off
④	Communication terminals	To connect Wi-Fi or other communication module
⑤	Meter communication and digital input	Input interface for electric meter communication and external digital input
⑥	DRM communication	Interface of demand response modes for Australia grid dispatching
⑦	Ventilation valve	To prevent from condensing and fogging, and balance differential pressure between inside and outside the cabinet
⑧	AC output terminals	To feed the inverter output energy into the grid
⑨	Mounting bracket	To fix the inverter on the wall mounting bracket

## 2.4 Weights and Dimensions of Inverter

Inverters	Weight	Dimensions (WxDxH)
2 kW / 2.5 kW / 3 kW	< 9 kg	308 mm x 116.5 mm x 353 mm
3 kW-D / 3.68 kW / 4 kW / 4.6 kW / 5 kW / 6 kW / 7kW	< 11.5 kg	370 mm x 126.5 mm x 420 mm

Dimensions of 2 kW / 2.5 kW / 3 kW inverter:

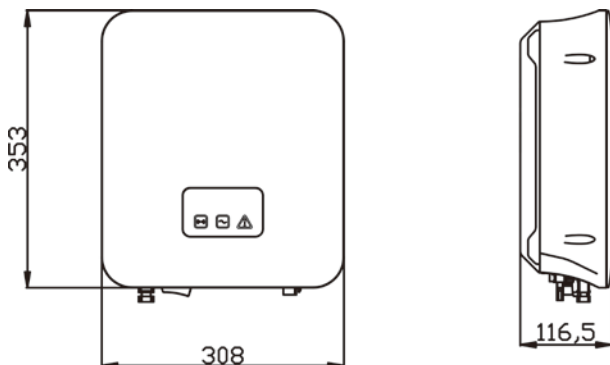



Dimensions of 3 kW-D / 3.68 kW / 4 kW / 4.6 kW / 5 kW / 6 kW / 7kW inverter:

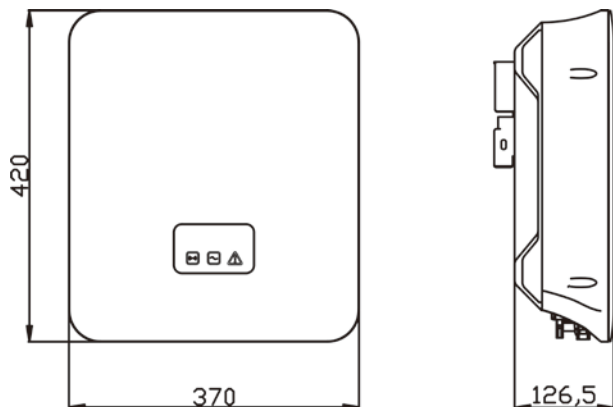

## 2.5 Specifications

Model	2 kW	2.5 kW	3 kW	3 kW - D	3.68 kW	4 kW	4.6 kW	5 kW	6 kW	7 kW
<b>Input (DC)</b>										
Max. input power (W)	2600	3250	3900	3900	4800	5200	6000	6500	7800	7800
Max. input voltage	600 V									
Start-up voltage	120 V									
Rated voltage	360 V									
MPPT voltage range	90 – 550 V									
MPPT voltage range at full load	200 – 480 V	250 – 480 V	300 – 480 V	150 – 480 V	200 – 480 V	200 – 480 V	230 – 480 V	250 – 480 V	300 – 480 V	350 – 480 V
Max. input current	11 A			11 A x 2						
Number of MPPTs	1			2						
<b>Output (AC)</b>										

Rated output power (W)	2000	2500	3000	3000	3680	4000	4600	4900 (AU S) 5000 (EU R)	6000	7000
Max. output current	8.7 A	10.9 A	13A	13 A	16A	17.4 A	20 A	21.3 A (AUS) 21.8 A (EUR)	26.1 A	30.5 A
Rated output voltage	230 Vac									
On-grid voltage range	180 – 280 Vac									
Rated frequency	50/60 Hz									
On-grid frequency range	45 – 55 Hz /55 – 65 Hz									
THD	< 3% (rated output power)									
Power factor (COS $\phi$ )	> 0.99									
<b>Efficiency</b>										
Max. conversion efficiency	97.8%									
European efficiency	97.3%									
<b>Others</b>										
Protection s	DC reverse polarity protection - DC input impedance monitoring - Leakage current protection - Output short-circuit protection - Islanding protection – Output DC component detection									

Communication	RS485*2, Wi-Fi / Ethernet	
Dimensions (WxDxH) (mm)	308 × 116.5 × 353	370 × 126.5 × 420
Weight	< 9 kg	< 11.5 kg
Operating temperature	- 25°C ~ + 60°C (> 45°C downgrading)	
Relative humidity	0% ~ 100%	
Altitude	4000 m (> 2000 m downgrading)	
IP rating	IP 65	
Cooling	Natural cooling	
Display	LED indicators	
Self-consumption at night	< 0.5 W	
Noise	< 40 dB	
Installation method	Wall-mounted	



**Note:** The above specifications are for reference only, please prevail in kind in the event of any inconsistency.

# 3 Unpacking and Storage

## 3.1 Unpacking Inspection

Although the product has been rigorously tested and inspected before delivery, damage may still occur during transport. Check that the delivery is complete, check the packaging and the inverter for externally visible damage, and inspect the package contents upon receipt. Notify the carrier and dealer if any damage is found or any component is missing.

### Scope of delivery:

No.	Designation	Quantity
1	Grid-Connected PV inverter	1 pcs
2	User manual	1 pcs
3	Quick guide	1 pcs
4	PV input terminal	1 set
5	AC output terminal	1 set
6	Communication module (Wi-Fi)	1 set
7	Expansion screws	4 sets
8	Hexagon socket head cap screws	2 pcs
9	Outer hex-cross screw with spring and plain washer	1 pcs
10	Wall mounting bracket	1 pcs
11	Waterproof terminal	1 set

## 3.2 Storage

If the inverter is not immediately put into operation, it needs to be stored in a specific environment:

- The inverter needs to be repackaged with the original packaging and the desiccant is retained. The packaging box needs to be sealed with tape.
- The inverter should be stored in a clean and dry place that free from dust and water vapor erosion.
- The temperature of the storage place should be kept at -30°C - +85°C and the relative humidity should be maintained between 0 and 100% without condensation.
- If the inverter should be stacked, it is recommended that the maximum number of layers can be accumulated no more than 5 layers.
- The inverter must avoid the corrosive chemicals, otherwise it may be corroded.
- It needs regular inspection during the storage, and the packaging materials should be replaced timely in the case of damage by rats and vermin.
- Do not tilt or invert the packaging box.
- After long-term storage, the inverter can't be put into operation until the comprehensive inspection and testing is made by qualified personnel.

# 4 Installation

## 4.1 Mounting Location

	<b>DANGER! Danger to life due to fire or explosion!</b>
	<ul style="list-style-type: none"><li>• Do not mount the inverter on flammable construction materials.</li><li>• Do not install the inverter in areas where highly flammable materials are stored.</li><li>• Do not install the inverter in areas with a risk of explosion.</li></ul>

In order to ensure that the inverter operates properly, the installation environment and requirements are as follows:

- The inverter is intended for outdoor use with IP 65 rating. The installation location should be cool and in good ventilation. Do not expose the inverter in the direct sunlight, otherwise, it may result in excessive temperature rise inside the inverter, downgrading operation of protection circuit and even shutdown due to over-temperature fault.
- Rain and snow do impact on the service life of the inverter, do not install the inverter in the rain and snow or do some appropriate shelter.
- The inverter adopts natural cooling, the ventilation and cooling are very important. Do not install the inverter in a closed enclosure, otherwise the inverter should be too hot to operate or even damaged.
- The inverter should be installed in the reinforced concrete wall or metal wall that can bear the weight of the inverter. The inverter must be installed vertically. Ensure that the installation place does not shaking.
- The inverter operation will generate some noise (< 40 dB), it should be installed away from the residential areas. Ensure that the installation location is convenient for viewing LED lights and LCD display screen. Sufficient clearances around the inverter must be reserved for ventilation, cooling, installation, maintenance and safe access.
- Do not install the inverter outdoors in salt areas because it will be corroded there and may cause fire. A salt area refers to the region within 500 meters from the coast or prone to sea breeze. The regions prone to sea breeze vary depending on weather conditions (such as typhoons and monsoons) or terrains (such as dams and hills).

	<b>CAUTION</b>
	Ambient temperature range shall be -25°C to +60°C. It will affect the inverter output power when the temperature exceeds the limit.
	Environmental relative humidity must be in the range of 0% ~ 100%.

## 4.2 Mounting the Inverter

### 4.2.1 Clearance

Note: Only install the inverter vertically or tilted backwards no more than 15 degrees. Do not tilt or install the inverter horizontally. The wiring terminal should be downwards.

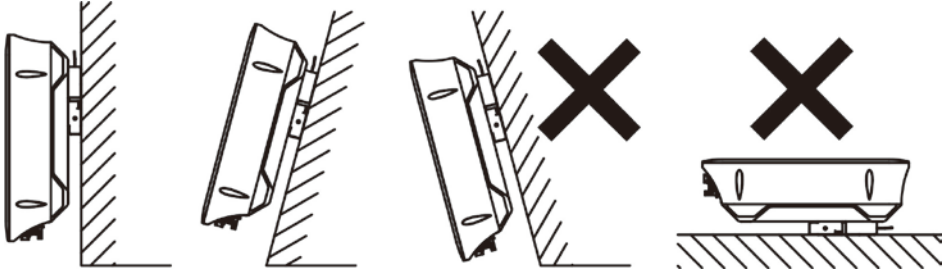

In order to maintain sufficient ventilation, when installing the inverter a minimum clearance of 30 cm at the sides and top must be maintained. Operation and reading are made easier by installing the inverter with its display at eye level and by keeping a distance of 30 cm from the front. All cables are routed to the outside through the underside of the enclosure, therefore a minimum clearance of 50 cm must be observed here.

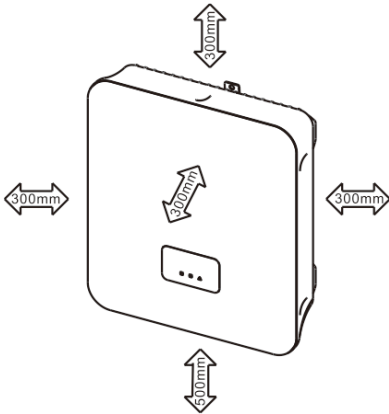

### 4.2.2 Installation Procedure

1. Place the wall mounting bracket against a suitable wall for mounting and align using a level. Mark the position of the drill holes using the wall mounting bracket.
2. Drill holes on the markings for them.
3. Secure the wall mounting bracket to the wall using expansion screws. Tighten the screws with a minimum torque of 30Nm, and M6 x 50 expansion bolts are recommended for use.

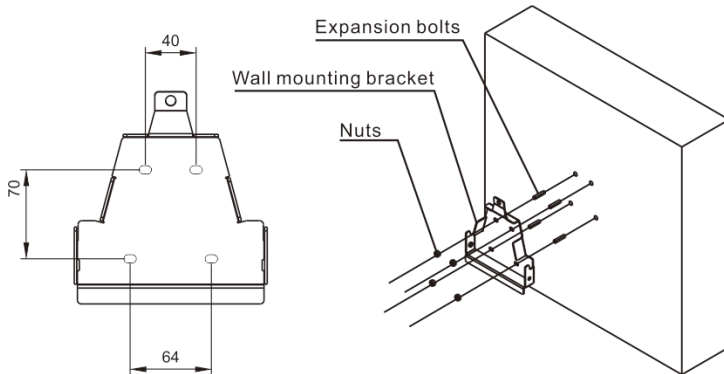

4. Attach the inverter to the wall mounting bracket. Screw the inverter to the wall mounting bracket on both sides using the M5 screws provided. Tighten the screws and make sure that they are securely in place.

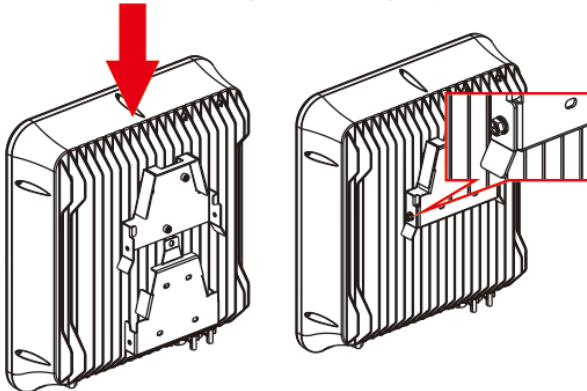

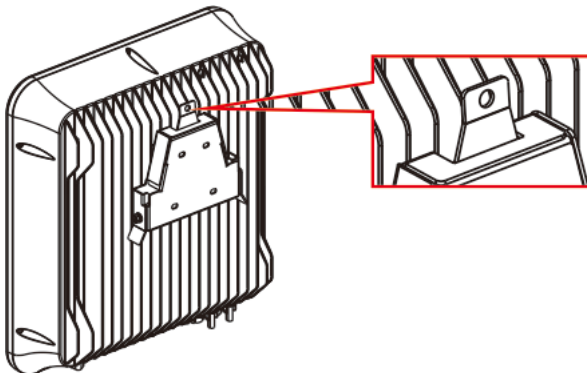

5. The Wall mounting bracket reserved a padlock hole to prevent the inverter from being stolen. The anti-theft lock needs to be prepared by the user himself.



# 5 Electrical Connection

## 5.1 Safety Precautions

	<b>DANGER!</b>
	<p>Improper wiring may result in fatal injury to operator or unrecoverable damage to the inverter. Only qualified personnel can perform the wiring operation. The breakers on the AC/DC sides of the inverter must be disconnected and the warning marks must be set before wiring.</p>
	<b>WARNING!</b>
	<p>The voltage and current parameters of the inverter must be considered when designing the PV system (see 2.5).</p>
	<b>WARNING!</b>
<p>Ensure that the electrical connection design is in compliance with the local national and local standards.</p>	
	<b>CAUTION</b>
	<p>The IP rating of this inverter is IP 65, please use the wiring terminal provided, otherwise the IP rating of the inverter may be reduced.</p>
	<b>CAUTION</b>
	<p>All cables must be connected firmly and reliably, properly insulated and avoid to be damaged easily.</p>
<b>CAUTION</b>	
<p>The inverter can only be connected to the utility grid after getting the approval from the local electric power department.</p>	



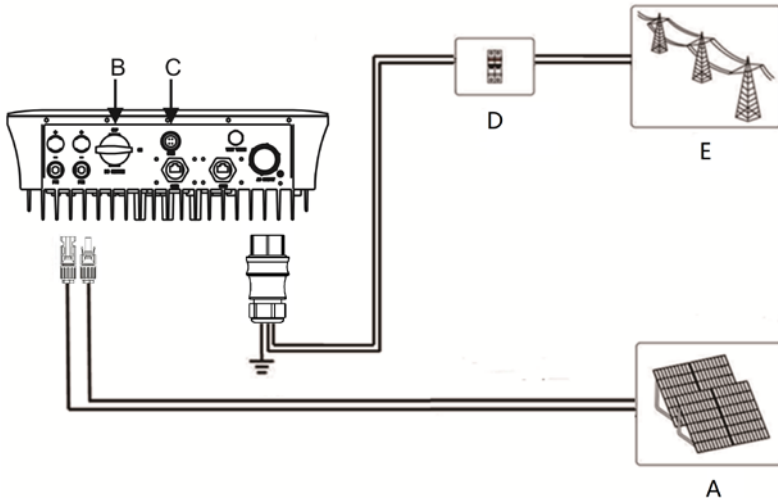

## 5.2 Electrical Connection Diagram



Electrical connection of the inverter includes connection on the DC side, connection on the AC side, communication modules connection, second protective earth connection and connection of anti-backflow meter.

No.	Item	Description
A	PV arrays	2 kW / 2.5 kW / 3 kW inverters are featured with single MPPT and single string input. 3kW-D / 3.68 kW / 4 kW / 4.6 kW / 5 kW / 6 kW / 7 kW inverters are double MPPT and two strings input. The maximum allowable open-circuit voltage of each PV string is 600V, and the maximum allowable working current of the each string input terminal is 11 A.
B	DC switch	Users can directly control DC input On / Off.
C	Communication modules	It is used to connect Wi-Fi or other communication module.
D	AC circuit breaker	It is used as a protective device during electrical connection. PE protection cable must be reliably grounded. It is recommended that 2 kW / 2.5 kW / 3 kW / 3kW-D inverters use AC circuit breakers of 25 A, 3.68 kW / 4 kW / 4.6 kW / 5 kW / 6 kW / 7 kW inverters use AC circuit breakers of 32 A. Each inverter requires a separate circuit breaker, and multiple inverters cannot share the same circuit breaker.
E	Utility grid	The rated voltage of the power grid is 230 V.

	<b>CAUTION</b>	
	Multiple inverters can be connected to a grid-connected grid, but it should not exceed 10 units. Otherwise, the inverter may not operate normally.	

	<b>CAUTION</b>	
	It is forbidden to connect the load between the inverter and the circuit breaker.	

### 5.3 Cable Requirements





Only waterproof terminals are included in scope of delivery. The user should select appropriate cables according to the following recommended cable size.

2 kW / 2.5 kW / 3 kW / 3 kW-D inverters	AC Output Terminals			PV Input Terminals	
	L	N	PE	Input +	Input -
Recommended Cross-sectional Area	4 mm <sup>2</sup>	4 mm <sup>2</sup>	4 mm <sup>2</sup>	4 mm <sup>2</sup>	4 mm <sup>2</sup>

3.68 kW / 4 kW / 4.6 kW / 5 kW / 6 kW / 7 kW inverters	AC Output Terminals			PV Input Terminals	
	L	N	PE	Input +	Input -
Recommended Cross-sectional Area	6 mm <sup>2</sup>	6 mm <sup>2</sup>	6 mm <sup>2</sup>	4 mm <sup>2</sup>	4 mm <sup>2</sup>

2 kW / 2.5 kW / 3 kW inverters are featured with one DC input, which can be connected with one PV string. 3kW-D / 3.68 kW / 4 kW / 4.6 kW / 5 kW / 6 kW / 7 kW inverters are featured with two DC input terminals, which can be connected with two PV strings. The output terminals on the AC side are marked with L, N, PE for easy installation. It is recommended that users use 4 mm<sup>2</sup> (2 kW / 2.5 kW / 3 kW / 3kW-D inverters) and 6 mm<sup>2</sup> (3.68 kW / 4 kW / 4.6 kW / 5 kW / 6 kW / 7 kW inverters) copper cables to perform connection.

## 5.4 DC Connection

	<p><b>DANGER !</b></p> <p>Before electrical connection, cover the PV battery modules with light-proof material and disconnect the circuit breaker on the DC side.</p>
	<p><b>WARNING !</b></p> <p>This product is a non-isolated inverter, the positive and negative electrodes of the PV module cannot be grounded, otherwise it will emit PV ISO Fault. The inverter cannot operate normally even be damaged.</p>
	<p><b>CAUTION</b></p> <p>When designing PV arrays, the open-circuit voltage of each PV string less than 600 V must be considered, and the maximum allowable short-circuit current for each PV string is no more than 12 A.</p>
	<p><b>NOTE</b></p> <p>2 kW / 2.5 kW / 3 kW inverters are featured with a single MPPT input and a group of input terminals, and a group of PV strings can be connected to the DC side. 3kW-D / 3.68 kW / 4 kW / 4.6 kW / 5 kW / 6 kW / 7 kW inverters are featured with two MPPT inputs and two groups of input terminals, and two groups of PV strings can be connected to the DC side.</p>

DC connection terminals are included in scope of delivery. Please connect the DC cables selected based on the above requirements to the connector by following the steps below. (Note: During connecting, use the same color for the positive cables with a mark and use another same color for negative cables with a mark. For example, generally red cables are used for the positive terminal and black cables are used for the negative .)

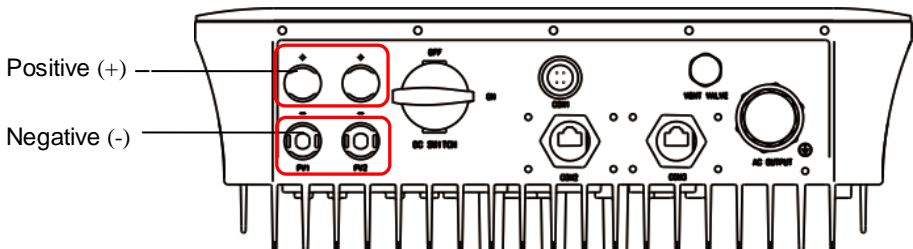

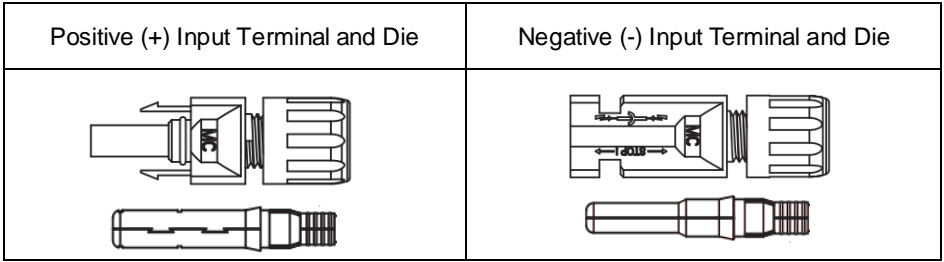

### Wiring on the DC side

1. Strip the DC cable insulation about 8 mm to expose the copper wire. Insert the cable copper wire into the metal core of the connector and tighten it with a crimper (As shown in the figure below).

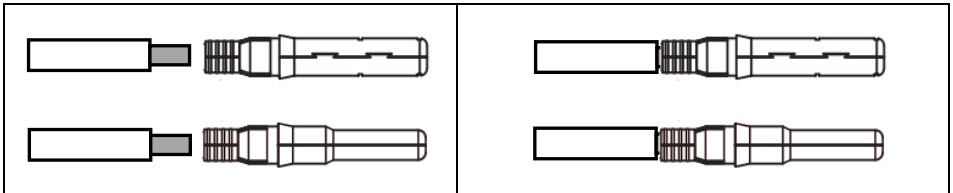

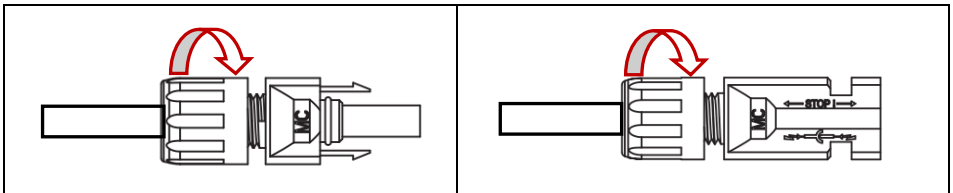

2. Loosen the terminal cover and pass the cable through the terminal cover. Insert the die into the wiring slot till you hear a sound indicating that the connection is in place. Tighten the terminal cover (As shown in the figure below).



3. Check whether the PV array cable connection polarity is correct with a voltmeter whose DC voltage measurement range is over 1000 V, and verify that the open-circuit voltage does not exceed the specification. When the ambient temperature is above 10°C, the open-circuit voltage of PV arrays can't exceed 90% of the maximum DC voltage of the inverter. Otherwise, at the low temperatures, the voltage of PV arrays may exceed the maximum input voltage of the inverter and cause damage to the inverter.
4. Disconnect the circuit breaker on the DC side and connect the PV input cable to the inverter separately.

## 5.5 AC Connection

	<b>WARNING !</b>
	Ensure that electrical connections are in compliance with the local national and local standards.

	<b>WARNING !</b>
	The uncharged metal parts in PV power generation systems consist of PV module bracket, the metal case of the inverter, which should be grounded reliably. The grounding pole should meet the standard requirements. The grounding parts of multiple inverters and PV arrays should be connected to the same grounding bus, building a reliable equipotential connection.

	<b>CAUTION</b>
	According to the requirement of EN50178, the right side of the inverter has a second earth terminal, which can be connected by the combination screws M4 x 8 with flat pad and spring pad.

### Wiring on the AC side

1. Pass the appropriate length of cable through the waterproof connector cap and shell. Strip the cable insulation about 10 mm (As shown in the figure below).

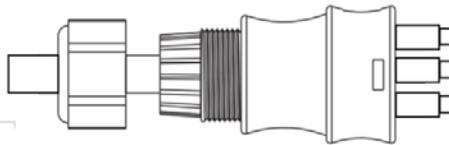

2. Fix L, N and PE wires to the corresponding AC terminals with a screwdriver and ensure that the PE wire is properly grounded (As shown in the figure below). (It is recommended to use soft copper core cables for uses)



3. Insert the shell into the AC terminal, hear a sound of "click", then tighten the waterproof connector cap.
4. Insert the AC connector into the AC output terminal, then turn the AC connector clockwise until hear a slight sound of "click", which indicates that the connection is in place (As shown in the figure below).

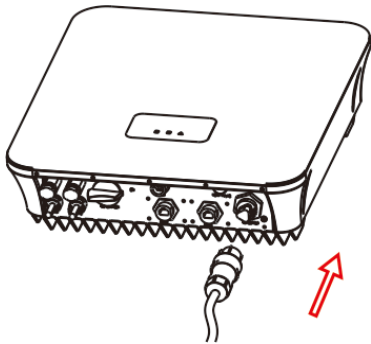

## 5.6 Second Protective Earth Connection

	<p><b>CAUTION</b></p>
<p>The PE point at the AC output port is used only as a PE equipotential point, and cannot substitute for the PE point on the enclosure.</p>	

	<p><b>DANGER !</b></p>
<p>Do not connect the neutral wire to the enclosure as a PE cable. Otherwise, electric shocks could occur.</p>	

There is a protective grounding hole at the bottom of the inverter. The user must make the inverter grounded through the grounding hole and tighten it with M4\*8 screws (As shown in the figure below).

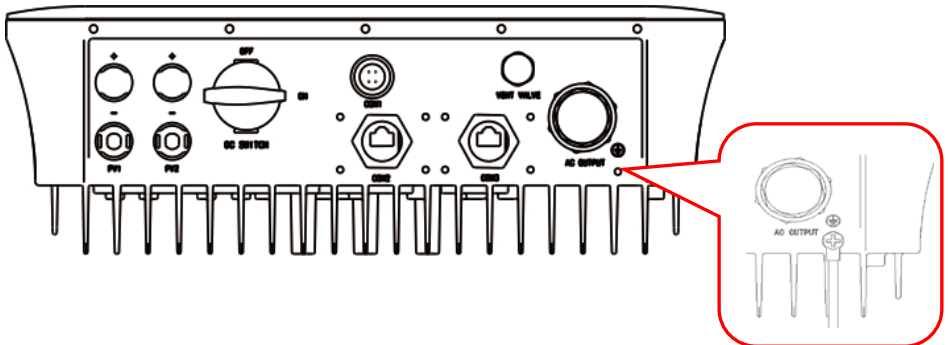

## 5.7 Connection of Anti-Backflow Meter (Optional)

The inverter equipped with anti-backflow function can perform power regulation and prevent feeding energy into the grid. Before using the anti-backflow function, the user should read the instructions carefully and correctly connect the cables as shown in the figure. Connection error may lead to unpredictable consequences, contact the maintenance personnel in this case.

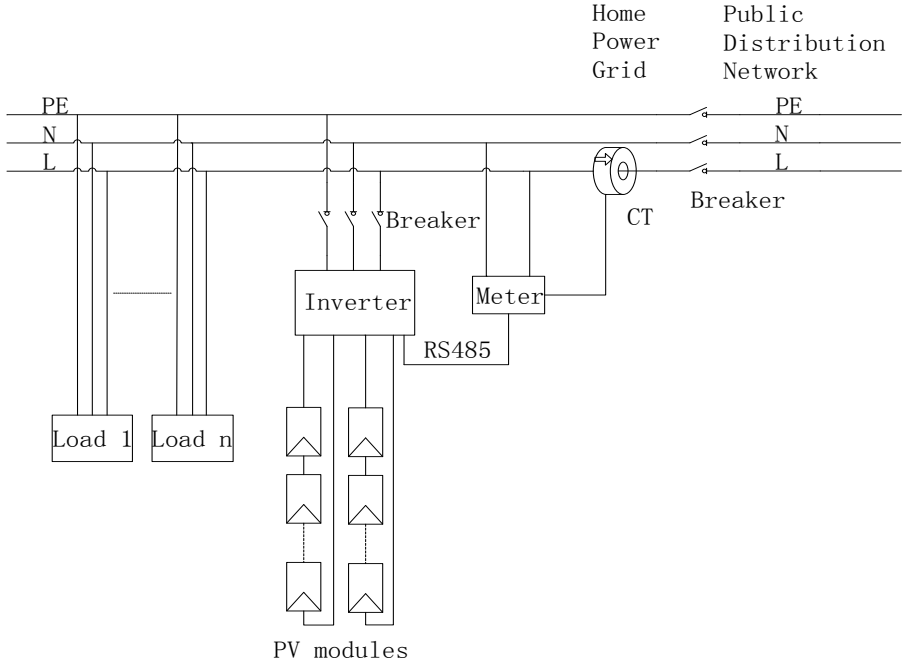

	<p><b>CAUTION</b></p> <p>The anti-backflow meter and current transformer (CT) should be installed at the front end of the connection point between the inverter, all loads and the grid (that is, close to the public power grid). The direction of the current transformer (CT) is from the user side to the public power grid side.</p>
--	---

Definition and wiring of the anti-backflow meter terminal are shown below.

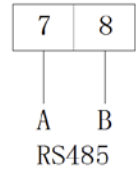
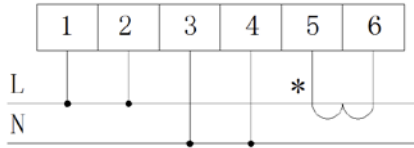
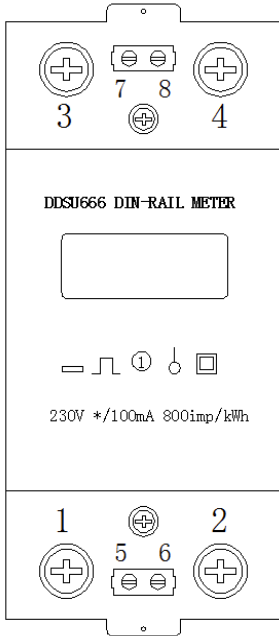

No.	Definition	Description
1	Live	No special requirements
2	Live	No special requirements
3	Neutral	No special requirements
4	Neutral	No special requirements
5	CT	White wire
6	CT	Black wire
7	A	No special requirements
8	B	No special requirements

As shown in the above figure, the anti-backflow meter terminals 7 & 8 are separately connected to the pin 8 and pin 6 of COM2.



## 6 Installing the Communication Module

Insert the Wi-Fi module into the COM1 communication interface at the bottom of the inverter and tighten the fastening screw.

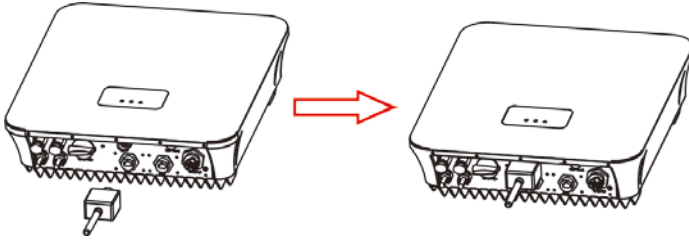

The RJ45 plug for electric meter communication and digital input is inserted into the COM2 connector, the RJ45 plug for DRM communication is inserted into the COM3 connector (only for Australian configuration).

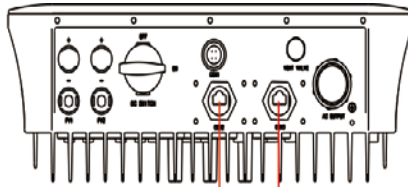

Meter communication and digital input

DRM Communication

The enlarged image of the meter communication interface and DRM communication interface is as shown below:

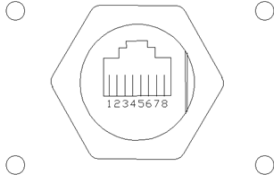

Meter communication interface (COM2) is illustrated as follows:

Pin	1	2	3	4	5	6	7	8
Definition	Blank	Blank	DI COM1	DI 1	Blank	B2	Blank	A2

DRM communication interface (COM3) is illustrated as follows:

Pin	1	2	3	4	5	6	7	8
Definition	DRM 1/5	DRM 2/6	DRM 3/7	DRM 4/8	REF GEN/0	COM LOAD/0	Shorted blank	

The RS485 communication interface of external meter – A and B are separately connected to the pin 8 and pin 6 of COM2 to realize the communication between the inverter and meter.



### CAUTION

Make sure the waterproof cover is tightly secured when external network cables are not connected to the COM2 and COM3 interfaces.  
Please install the waterproof terminal to ensure the waterproof performance of the inverter when external network cables are connected to the COM2 and COM3 interfaces.

### Wiring of COM2 and COM3

1. Pass the cable through the waterproof terminal, press the RJ45 crystal plug with a crimping tool, and insert the crystal plug into the housing of waterproof terminal.

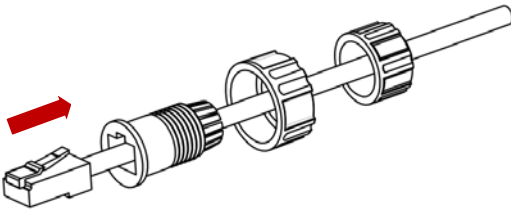

2. Insert the RJ45 crystal plug into the RJ45 port at the bottom of the inverter chassis then tighten the screw nut.

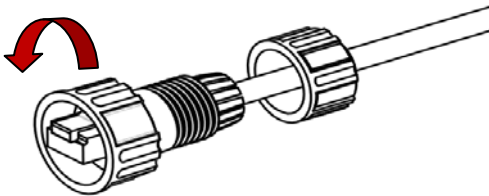

3. Tighten the sealing nut at the tail of the waterproof terminal.

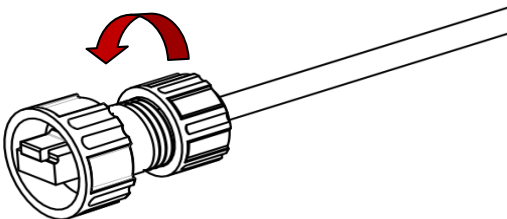

# 7 Operation

## 7.1 Switching On



1. Follow the above instructions to complete the connection of PV arrays and wiring on the AC/DC side of the inverter.
2. Before turning on the inverter, verify the following items:
  - The inverter is installed correctly and securely. The installation environment is convenient for operation and maintenance.
  - The communication module is connected correctly.
  - Electrical specifications of the AC breaker meet the requirements and it is installed correctly.
  - Cables are connected correctly, the electrified bodies are insulated and sealed to ensure safety.
  - Safety and warning labels are prominent and clear.
  - Voltage on the grid side and the DC side meet the requirements of the inverter.
3. Close the circuit breaker on the AC side.
4. Close the DC switch of the inverter. If the input voltage is within the range of requirement, the green LED indicator lights and flashes, and the inverter starts detecting.
5. When the illumination conditions meet the working requirements of the inverter, the inverter will automatically start running and deliver power to the grid. The green LED indicator is always lit.
6. There is no need to be manual controlled when the inverter is successfully connected to the utility grid and runs automatically.
7. The inverter shuts down automatically if faults occur and the red LED indicator lights. Refer to Section 7.3 for LED indicators descriptions. After the fault is removed, the inverter will restart automatically.

## 7.2 Switching Off

1. When the illumination is insufficient to keep the inverter running, the inverter shuts down automatically.
2. When a fault occurs, the inverter displays the fault code automatically. Disconnect the AC circuit breaker and the DC switch of the inverter if emergency shutdown is required.

### 7.3 LED Indicator Lights

The current status of operating and communications of the inverter can be viewed via the three LED indicator lights on the panel (as shown in following table).

LED	Display Status	Explanation
	Illuminated	Communication is normal
	Extinguish	Communication module is disconnected
	Illuminated	Inverter is in grid-connected power generation status
	Flashes at 1 second interval	Inverter is waiting for on-grid or in the started state
	Illuminated	Inverter fault
	Flashes quickly at 0.2 seconds interval	Grid fault
	Flashes slowly at 1 second interval	PV input fault

Note: If both the green LED indicator and the red LED indicator are flashing at the same time, it indicates that a program upgrade is in progress. Do not perform any operation before the program upgrade is completed.

# 8 Monitoring

This series of inverters doesn't have an LCD display screen, therefore the wireless communication module is required to view the running state. Please refer to section 6 for the installation of wireless communication module. After installing the Wi-Fi communication module, users can download a mobile App to monitor the running state of the whole PV system.

## 8.1 Professional Edition App

The user can view the running status of the inverter, configure the operational parameters and upgrade the software via the professional App. Professional App is recommended for professionals, operation and maintenance personnel.

### 8.1.1 Software Installation

Search "solarmanPro" in Apple Store to download the App for iPhones. Search "solarmanPro" in Google Play to download the App for Android phones.

### 8.1.2 Registration & Login

**Registration:** Enter App after downloading "solarmanPro". Click on [Free Account], then enter registration information and follow [Next] procedures until [Applied], as shown below.

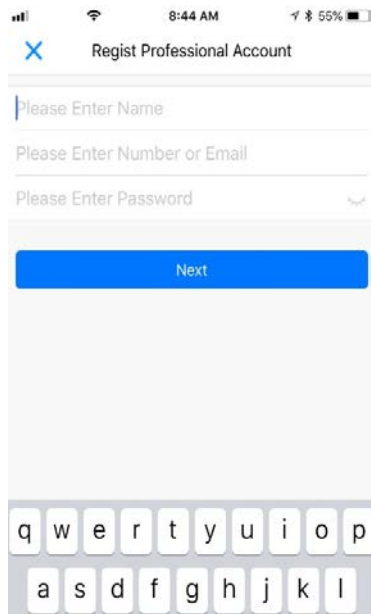
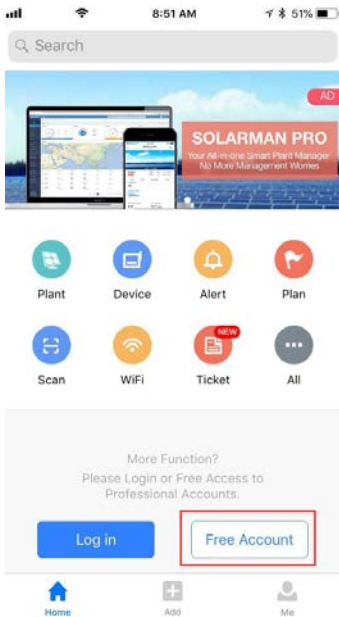

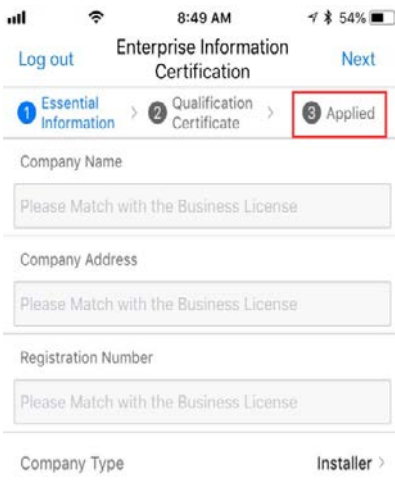
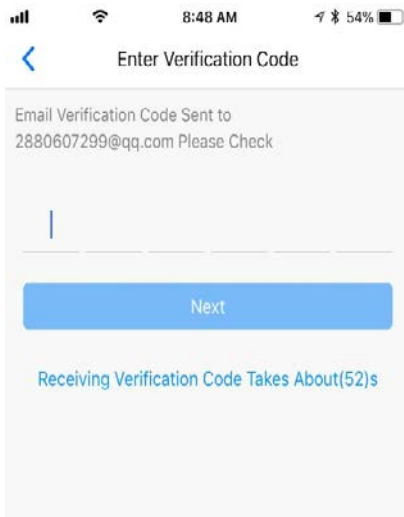

**Login:** Click on [Log in] in the App home page, and enter your email and password.

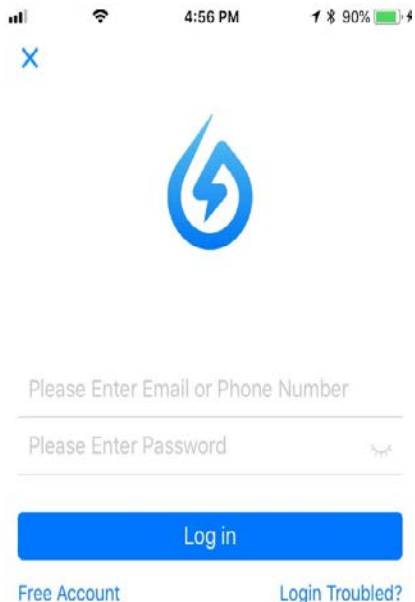
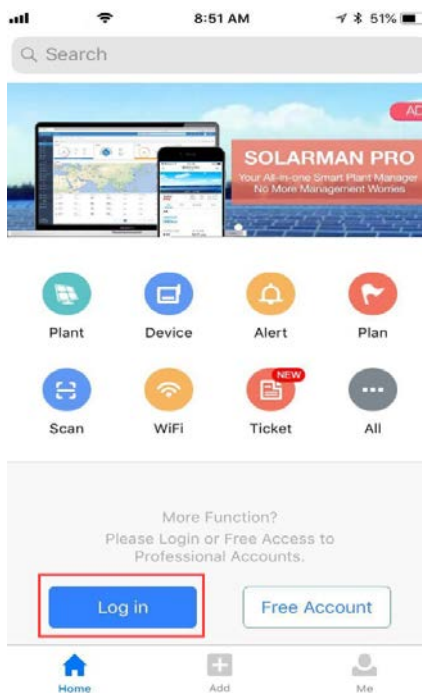

### 8.1.3 Create Plant

1. Method 1: Click on [Add] in the App home page, and click the [Plant] icon from the pop-up menu, then scan the serial number of the stick logger.

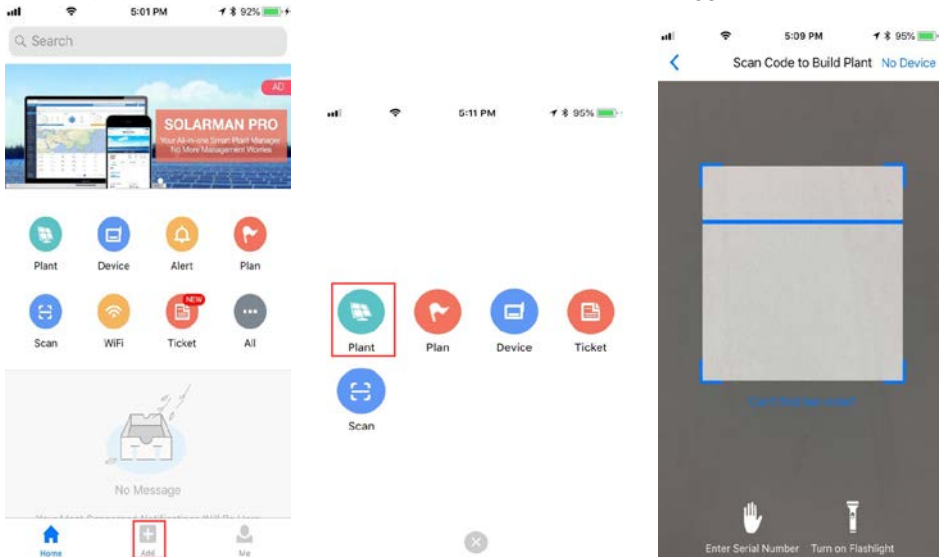

Method 2: click the [Plant] icon first to enter the plant list, then click [+] in the upper right corner to add the plant, then scan the serial number of the stick logger.

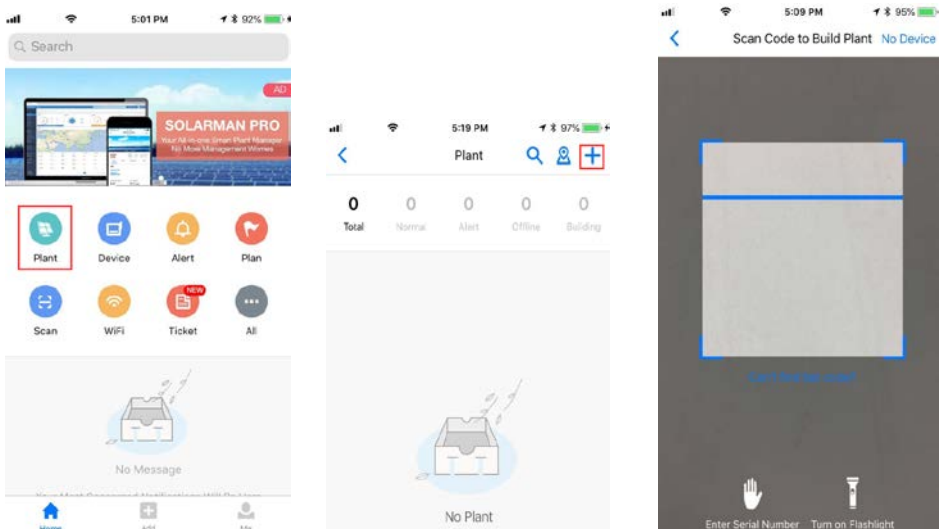

Note: If fail to scan by method 1 and method 2, you can manually enter the serial number.

## 2. Edit the plant information

Enter the interface of plant information after successfully scanning the serial number or clicking on [No Device].

- Confirm your plant location. GPS function will automatically locate the plant site. If you are absent at the scene of the plant, or want to modify the location, click the



[map] icon  to find the correct plant location.

- Select your plant type.
- Select your grid type.
- Fill in plant capacity.

(You may keep the default settings in the rest of blank because App has received local electricity prices and subsidies)

Back    Ensure Plant Information    Next

Plant Location

Longitude 113°54'24"     

Latitude 22°58'5"

Plant Address

NO. No.6 Building B Gongye North Road Gu...

Plant Type

Home    Industrial    Business    Utility

On-grid Type

Distributed Rest Poer on Grid    Distributed All Power on Grid

Ground Plant All Power on Grid    Offline    Storage System

Capacity(kWp)    5



3. Enter the plant name. It is suggested to create a plant name like "location + name + capacity", then click on [Done].

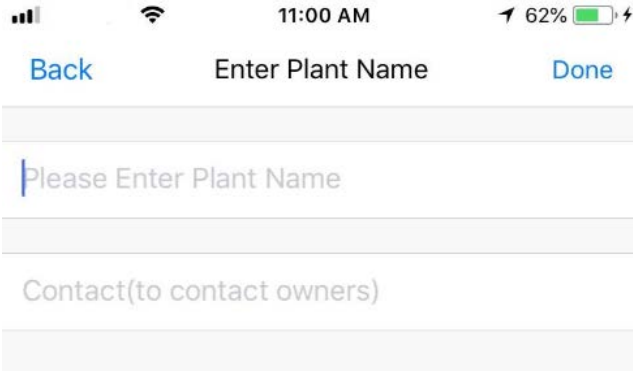

4. Then the plant you added is shown on the homepage.

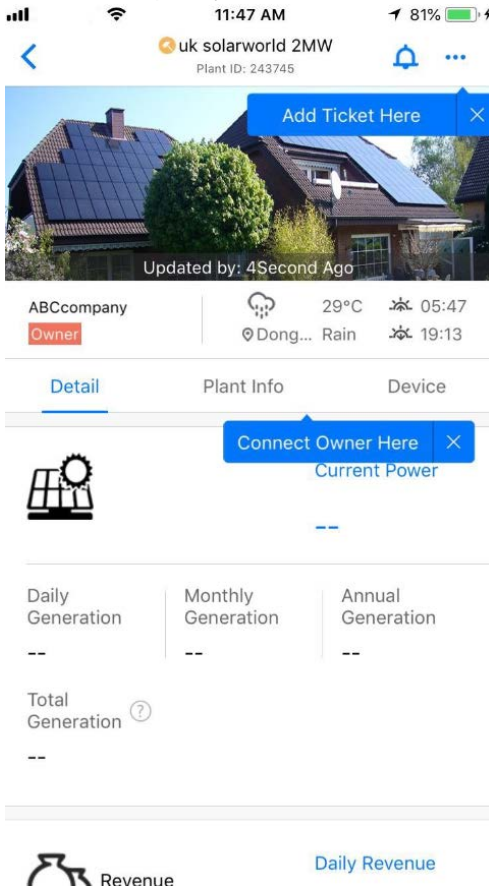

## 8.2 Home Edition App

Home edition APP is mainly used for residential PV system. It collects power generation information and operation information to enable users to obtain the running status information of the inverter in time.

### 8.2.1 Software Installation

Search “solarman” in Apple Store to download the App for iPhones, Search “solarman” in Google Play to download the App for Android phones.

### 8.2.2 Registration & Login

Click on [Register] to create new account, and enter your email to register.

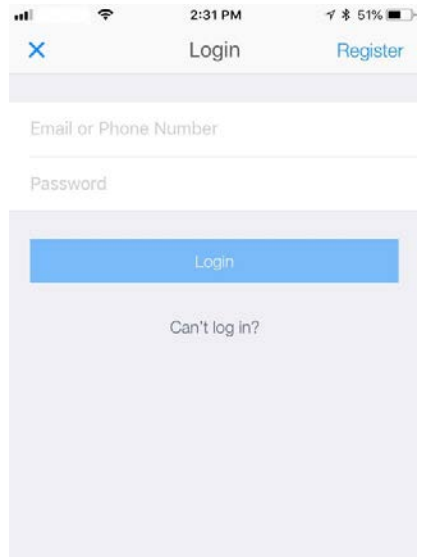

## 8.2.3 Create Plant

1. After login, click [+] in the upper right corner and follow the on-screen instructions. Then scan the serial number of the stick logger, or manually enter the serial number.

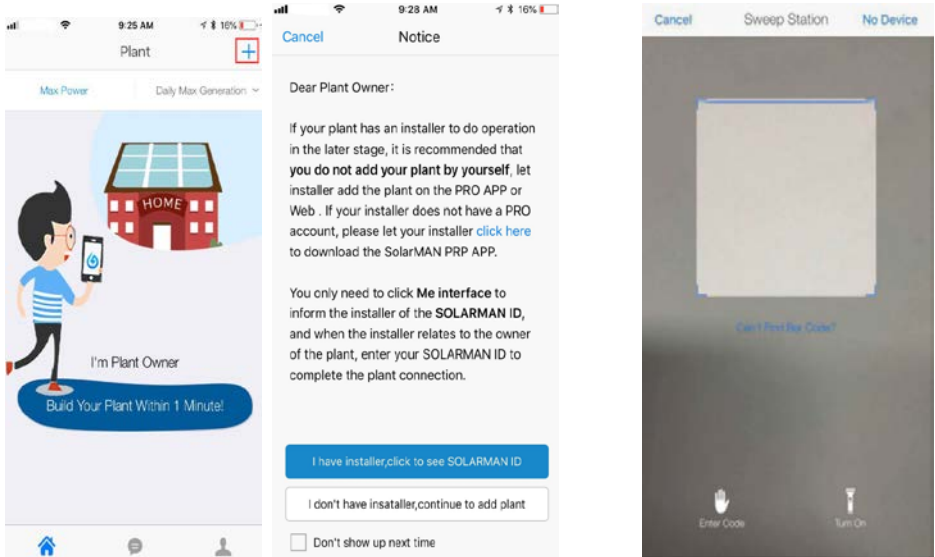

### 2. Edit Plant Information

- Confirm your plant location. GPS function will automatically locate the plant site. If

you want to modify the location, click the [map] icon , and then manually enter the plant address.

- Select your plant type.
- Select your grid type.
- Fill in plant capacity.  
(You may keep the default settings in the rest of blank because App has received local electricity prices and subsidies)

Back Confirm Plant Info Next

Plant Location 1

Longitude 120°21'37"

Latitude 31°30'23"

Plant Address

Tian'an Intelligent Park A3 Industrial Building Tian **b**

Plant Type 2

Resi Roof Industrial Commercial Utility

Grid Type 3

Distributed Self Use Left on Grid Distributed All Power on Grid

Ground All Power on Grid Offline Storage System

Capacity(KW) 4 5

Directions



3. Enter the plant name. It is suggested to create a plant name like "location + name + capacity", then click on [Done].

Back Enter the plant name Done

Plant Name

Phone number (Easy to contact you)

4. Then the plant you added is listed on the homepage.

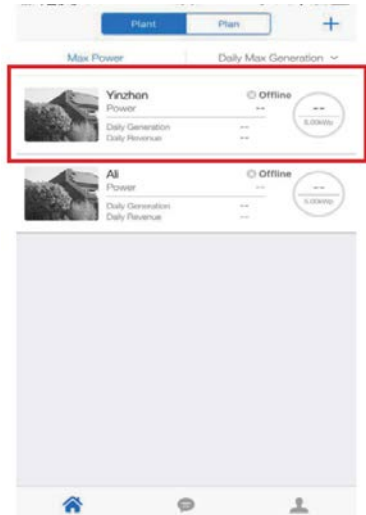

## 9 Troubleshooting for Fault Messages Displayed on APP

<b>Fault Messages</b>	<b>Description</b>	<b>Corrective Action</b>
Grid overvoltage / undervoltage	Voltage on AC side exceeds the allowable range	Check if the grid voltage is within the allowable range. Contact the local operation and maintenance personnel for any help.
Grid over-frequency / under-frequency	Frequency on AC side exceeds the allowable range	Check if the grid frequency is within the allowable range. Contact the local operation and maintenance personnel for any help.
No grid	Fail to detect the voltage on AC side	Check the connection of AC circuit breaker, AC fuse and AC terminals. Contact the local operation and maintenance personnel for any help.
PV reversely connected	Positive and negative polarity of DC input PV 1 or PV 2 are reversely connected	Contact the local operation and maintenance personnel for any help.
PV overvoltage	DC input voltage is excessive	Contact the local operation and maintenance personnel for any help.
Insulation impedance fault	Ground impedance of PV modules is less than the allowable value	Check the connection of PV arrays and earth wire, then restart the inverter. Contact the local operation and maintenance personnel for any help.
Leakage current abnormality	Leakage current exceeds the allowable value	Check the connection of PV arrays and earth wire, then restart the inverter. Contact the local operation and maintenance personnel for any help.